

**CUSCINETTI MAGGIORATI
PER LAVORAZIONI PESANTI**

Reinforced bearings for
heavy machining

Vergroesserte Lager fuer
schwerere Bearbeitungen

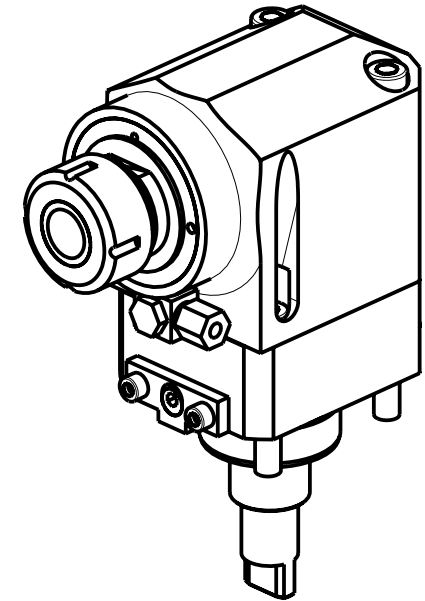

Cod. MT	Cod. BIGLIA	Mandrino Spindle Spindel	I	RPM	Reversibile lato mandrino/contromandrino Reversible sub/main spindle side Umkehrbare Spindel-seite/ Gegenspindel-seite	Lubrificazione int. Coolant through Innenkuehlung	Lubrificazione est. Ext. coolant Aussenkuehlung	A	B	CHIAVI NON INCLUSE Keys not included Schluessel nicht einbegriffen	
0391432L	-	ER32	1:1	4000	X		X	111.56	50	CHSTER32	CHUB36
0391032L	-	ER32	1:1	4000	X	P=70bar	X	111.56	72	CHSTER32	CHUB36
0392640L	-	ER40	1:1	4000	X		X	115.16	50	CHSTER40	CHUB46
0392540L	-	ER40	1:1	4000	X	P=70bar	X	115.16	72	CHSTER40	CHUB46

BIGLIA

MOD: B445/470/545/550/565/650/658/1200

MODULO MOTORIZZATO ASSIALE MAGGIORATO H100

Reinforced axial driven tool H100

Axial angetriebenes Werkzeug vergroessert H100

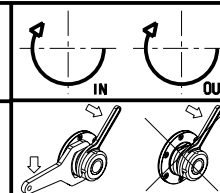

M.T. srl

Via dei Tamerici 1/3
Tel. 0541/956034-957884

Fax 0541/956341

47842 S. GIOVANNI IN M. (RN)

e-mail: mima@mtmarchetti.com

http://www.mtmarchetti.com

PRODUZIONE MODULI ROTANTI



PAGINA BGL170-1-20