

ATTENZIONE - ATTENTION - ACHTUNG

- Su macchine B545, B550, B565 non arriva in centro mandrino
- On machines B545, B550, B565 tool does not get to the centre of the spindle axis.
- Auf Maschinen B545, B550, B565 erreicht das Werkzeug nicht die Mitte der Werkzeug-Achse.

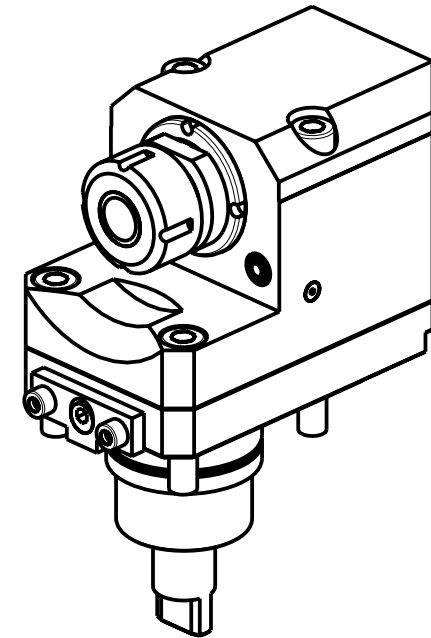

Cod. MT	Cod. BIGLIA	Mandrino Spindle Spindel	I	RPM	Reversibile lato mandrino/contromandrino Reversible sub/main spindle side Umkehrbare Spindel-seite/ Gegenspindel-seite	Lubrificazione int. Coolant through Innenkuehlung	Lubrificazione est. Ext. coolant Aussenkuehlung	A	CHIAVI NON INCLUSE Keys not included Schlüssel nicht einbegriffen	
0220025	-	ER25	1:1	4000	X		X	30	CHSTER25	CHUB36
0220032	-	ER32	1:1	4000	X		X	39	CHSTER32	CHUB36

BIGLIA

MOD: B301/445/470/501(Y-S)/510/545/550/565/650/658/1200

MODULO MOTORIZZATO ASSIALE ARRETRATO

Axial rear-set driven tool

Axial angetriebenes Werkzeug zurueckversetzt

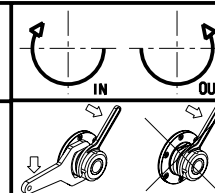

M.T. srl

Via dei Tamerici 1/3
Tel. 0541/956034-957884

Fax 0541/956341

47842 S. GIOVANNI IN M. (RN)

e-mail: mtma@mtmarchetti.com

http://www.mtmarchetti.com

PRODUZIONE MODULI ROTANTI



PAGINA BGL180-1-10