

ATTENZIONE - ATTENTION - ACHTUNG

- Su macchine B545, B550, B565 non arriva in centro mandrino
- On machines B545, B550, B565 tool does not get to the centre of the spindle axis.
- Auf Maschinen B545, B550, B565 erreicht das Werkzeug nicht die Mitte der Werkzeug-Achse.

ATTENZIONE - ATTENTION - ACHTUNG

- Per lo smontaggio degli utensili utilizzare sempre la chiave di contrasto come indicato nel manuale d'uso.
- For disassembly of the tools use always the contrast key as mentioned in the user instructions.
- Fuer das Abmontieren der Werkzeuge immer den Gegenschuessel benutzen wie in der Bedienungsanleitung erwaeht.

ATTENZIONE - ATTENTION - ACHTUNG

- PRIMA DI UTILIZZARE IL MOTORIZZATO CONSULTARE LE ISTRUZIONI ALLEGATE!
- BEFORE USING THE DRIVEN TOOL, PLEASE CHECK THE ENCLOSED INSTRUCTION SHEET!
- VOR DER BENUTZUNG DES ANGETRIEBENEN WERKZEUGES, DIE BEILIEGENDEN INSTRUKTIONEN DURCHLESEN!

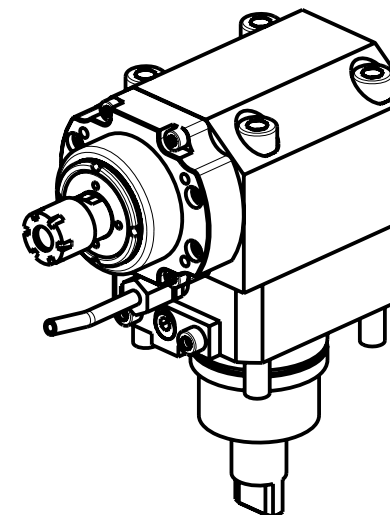
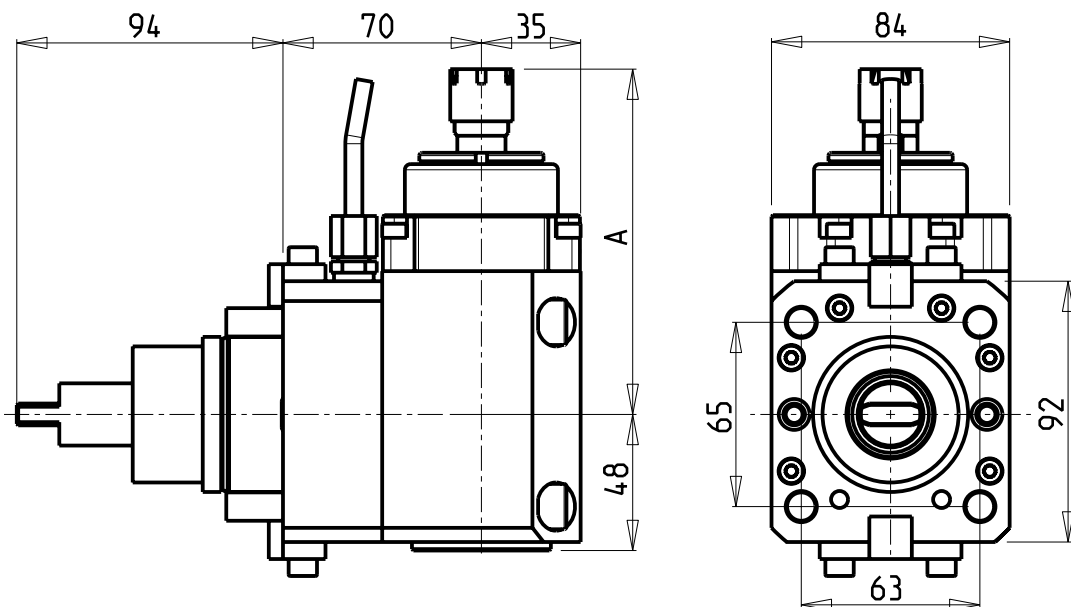

Cod. MT	Cod. BIGLIA	Mandrino Spindle Spindel	I	RPM	Reversibile lato mandrino/contromandrino Reversible sub/main spindle side Umkehrbare Spindel-seite/ Gegenspindel-seite	Lubrificazione int. Coolant through Innenkuehlung	Lubrificazione est. Ext. coolant Aussenkuehlung	A	CHIAVI INCLUSE Keys included Schuessel einbegriffen	
0460016	-	ER16	1:5.625	22500	X		X	121.8	CHMNER16	CHUB17
0460011	-	ER11	1:5.625	22500	X	P=70bar		134	CHMNER11	CHUB11

BIGLIA

MOD: B301/445/470/501(Y-S)/510/545/550/565/650/658/1200

MODULO MOTORIZ. ASSIALE MOLTIPLICATO I = 1:5.625

Geared-up axial driven tool I=1:5.625

Axial angetriebenes Werkzeug uebersetzt I=1:5.625

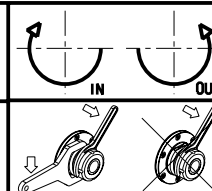

M.T. srl

Via dei Tamerici 1/3
Tel. 0541/956034-957884
Fax 0541/956341

47842 S. GIOVANNI, IN M. (RN)
e-mail: mima@mlmarchetti.com
http://www.mlmarchetti.com

PRODUZIONE MODULI ROTANTI



PAGINA BGL210-1-10