

ATTENZIONE - ATTENTION - ACHTUNG

- Per lo smontaggio degli utensili utilizzare sempre la chiave di contrasto come indicato nel manuale d'uso.
- For disassembly of the tools use always the contrast key as mentioned in the user instructions.
- Fuer das Abmontieren der Werkzeuge immer den Gegenschlüssel benutzen wie in der Bedienungsanleitung erwäehnt.

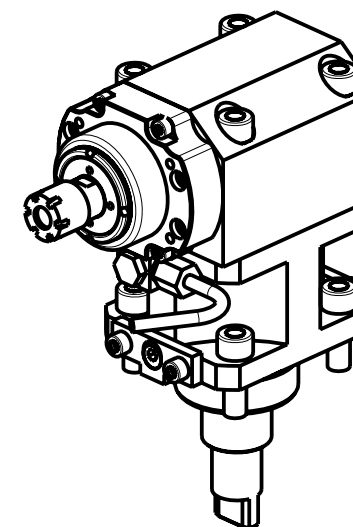

ATTENZIONE - ATTENTION - ACHTUNG

- PRIMA DI UTILIZZARE IL MOTORIZZATO CONSULTARE LE ISTRUZIONI ALLEGATE!
- BEFORE USING THE DRIVEN TOOL, PLEASE CHECK THE ENCLOSED INSTRUCTION SHEET!
- VOR DER BENUTZUNG DES ANGETRIEBENEN WERKZEUGES, DIE BEILIEGENDEN INSTRUKTIONEN DURCHLESEN!

| Cod. MT | Cod. BIGLIA | Mandrino Spindle Spindel | I | RPM | Reversibile lato mandrino/contromandrino Reversible sub/main spindle side Umkehrbare Spindel-seite/ Gegenspindel-seite | Lubrificazione int. Coolant through Innenkuehlung | Lubrificazione est. Ext. coolant Aussenkuehlung | A | CHIAVI INCLUSE Keys included Schlüssel einbegriffen | |
|----------|-------------|--------------------------|---------|-------|---|---|---|-------|---|--------|
| | | | | | | | | | | |
| 0460016L | - | ER16 | 1:5.625 | 22500 | X | | X | 121.8 | CHMNER16 | CHUB17 |
| 0460011L | - | ER11 | 1:5.625 | 22500 | X | P=70bar | | 134 | CHMNER11 | CHUB11 |

BIGLIA

MOD: B445/470/545/550/565/650/658/1200

MODULO MOTORIZ. ASSIALE MOLTIPLICATO H 100 I = 1:5.625

Geared-up axial driven tool H 100 I=1:5.625

Axial angetriebenes Werkzeug uebersetzt H 100 I=1:5.625

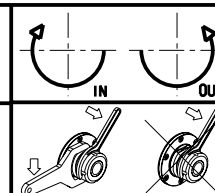

M.T. srl

Via dei Tamerici 1/3
Tel. 0541/956034-957884

Fax 0541/956341

47842 S. GIOVANNI IN M. (RN)

e-mail: mima@mtmarchetti.com

http://www.mtmarchetti.com

PRODUZIONE MODULI ROTANTI



PAGINA BGL210-1-20