

**ATTENZIONE - ATTENTION - ACHTUNG**

- Su macchine B545, B550, B565 non arriva in centro mandrino
- On machines B545, B550, B565 tool does not get to the centre of the spindle axis.
- Auf Maschinen B545, B550, B565 erreicht das Werkzeug nicht die Mitte der Werkzeug-Achse.

**ATTENZIONE - ATTENTION - ACHTUNG**

- Per lo smontaggio degli utensili utilizzare sempre la chiave di contrasto come indicato nel manuale d'uso.
- For disassembly of the tools use always the contrast key as mentioned in the user instructions.
- Fuer das Abmontieren der Werkzeuge immer den Gegenschlüssel benutzen wie in der Bedienungsanleitung erwäehnt.

**ATTENZIONE - ATTENTION - ACHTUNG**

- PRIMA DI UTILIZZARE IL MOTORIZZATO CONSULTARE LE ISTRUZIONI ALLEGATE!
- BEFORE USING THE DRIVEN TOOL, PLEASE CHECK THE ENCLOSED INSTRUCTION SHEET!
- VOR DER BENUTZUNG DES ANGETRIEBENEN WERKZEUGES, DIE BEILIEGENDEN INSTRUKTIONEN DURCHLESEN!

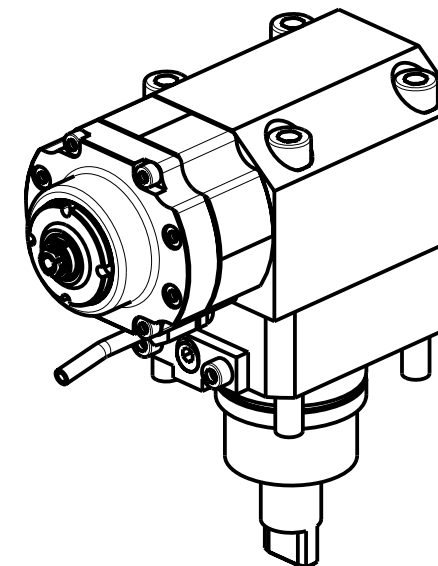
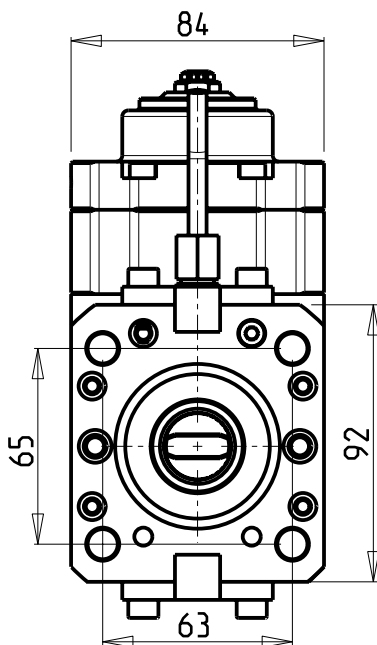
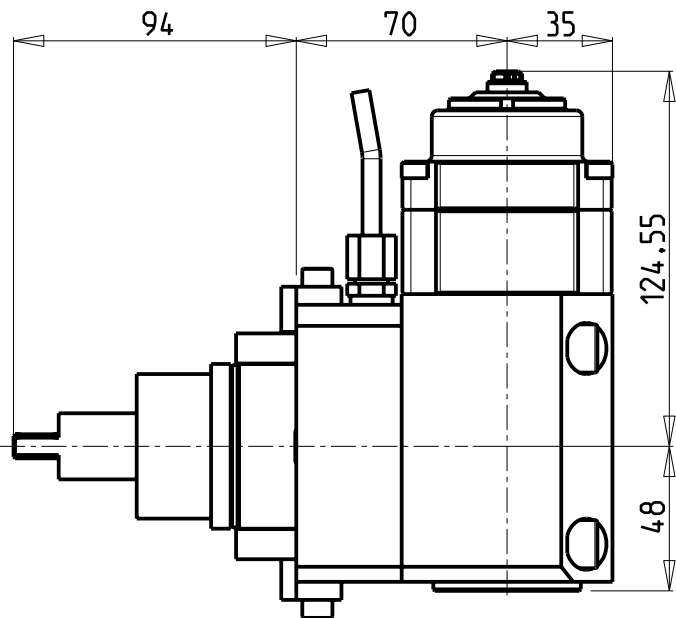

Cod. MT	Cod. BIGLIA	Mandrino Spindle Spindel	I	RPM MAX	Reversibile lato mandrino/contromandrino Reversible sub/main spindle side Umkehrbare Spindel-seite/ Gegenspindel-seite	Lubrificazione int. Coolant through Innenkuehlung	Lubrificazione est. Ext. coolant Aussenkuehlung	CHIAVI INCLUSE Keys included Schlüssel einbegriffen	
0480855	-	CHG	1:17.015	60000	X		X	CHUB10	CHUB13

**BIGLIA**

MOD: B301/445/470/501(Y-S)/510/545/550/565/650/658/1200

MOD. MOTOR. ASSIALE MOLTIPLICATO I = 1:17.015 PINZA CHG

Geared-up axial driven tool with CHG collet I=1:17.015

Axial angetr. Werkz. uebersetzt I=1:17.015 mit Zange CHG

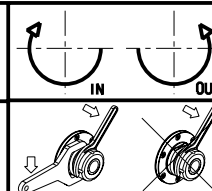

**M.T. srl**

Via dei Tamerici 1/3  
Tel. 0541/956034-957884  
Fax 0541/956341

47842 S. GIOVANNI IN M. (RN)  
e-mail: mima@mtmarchetti.com  
http://www.mtmarchetti.com

PRODUZIONE MODULI ROTANTI



PAGINA BGL220-1-10