

ATTENZIONE - ATTENTION - ACHTUNG

- Su macchine B545, B550, B565 non arriva in centro mandrino
- On machines B545, B550, B565 tool does not get to the centre of the spindle axis.
- Auf Maschinen B545, B550, B565 erreicht das Werkzeug nicht die Mitte der Werkzeug-Achse.

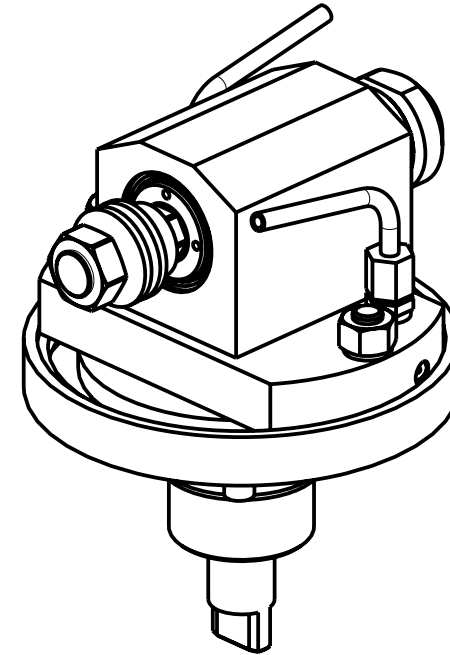
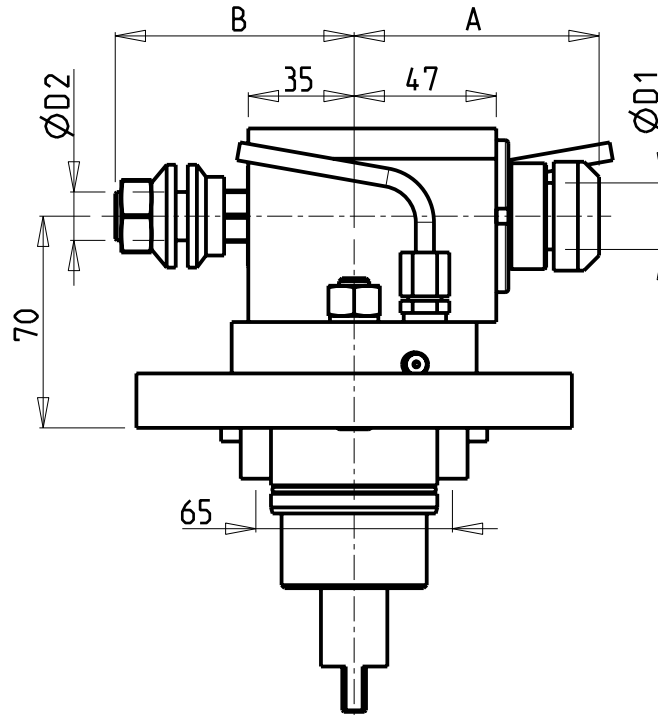
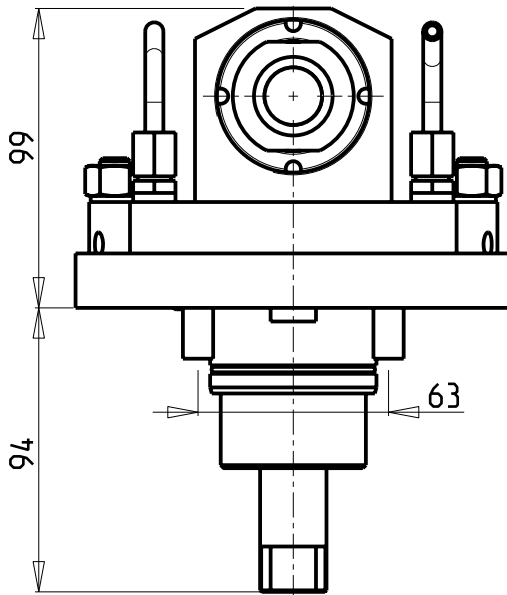

Cod. MT	Cod. BIGLIA	Mandrino Spindle Spindel	I	RPM	Lubrificazione est. Ext. coolant Ausseukuehlung	A	B	D1	D2	NOTA Note Note	CHIAVI INCLUSE Keys included Schluessel inbegriffen		
0062216	-	Ø22+Ø16	1:1	4000	X	81	79	22	16	PORTAFRESA A DISCO MILLING CUTTER HOLDER DISK FLASHALTER	CHUB36	CHUB24 + CHUB17	CHESL07
0060825	T134-00082	ER25	1:1	4000	X	80.16	-	-	-		CHUB36	CHSTER25	CHESL07
0062516	-	ER25+ER16	1:1	4000	X	80.16	66	-	-		CHUB36	CHSTER25 + CHMNER16	CHESL07

BIGLIA  
 MOD: B301/445/470/501(Y-S)/510/545/550/565/650/658/1200

MODULO MOTORIZZATO ASSIALE ANGOLARE ±180°  
 Adjustable angle ±180° axial driven tool  
 Axial angetriebenes Werkzeug schwenkbar ±180°

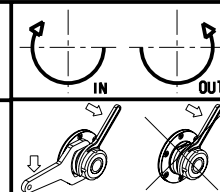

**M.T. srl**  
 Via dei Tamerici 1/3  
 Tel. 0541/956034-957884  
 Fax 0541/956341  
 47842 S. GIOVANNI IN M. (RN)  
 e-mail: mima@mtmarchetti.com  
 http://www.mtmarchetti.com

PRODUZIONE MODULI ROTANTI



PAGINA BGL355-1-00