

ATTENZIONE - ATTENTION - ACHTUNG

- VERIFICARE LE MISURE DI INGOMBRO PER POSSIBILE INTERFERENZA SU B650 ; B658 ; B1200
- Please check the overall sizes for possible interferences on B650 ; B658 ; B1200
- Bitte überprüfen sie das ausmass um mögliche interferenzen auf B650 ; B658 ; B1200 zu vermeiden

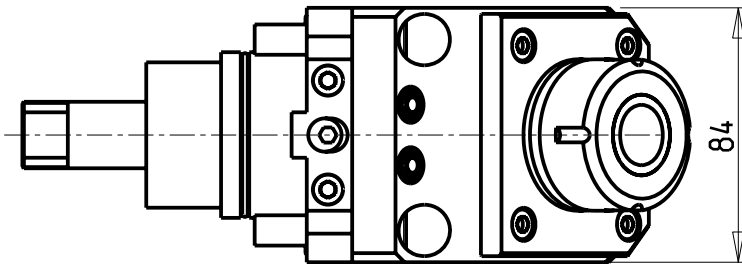
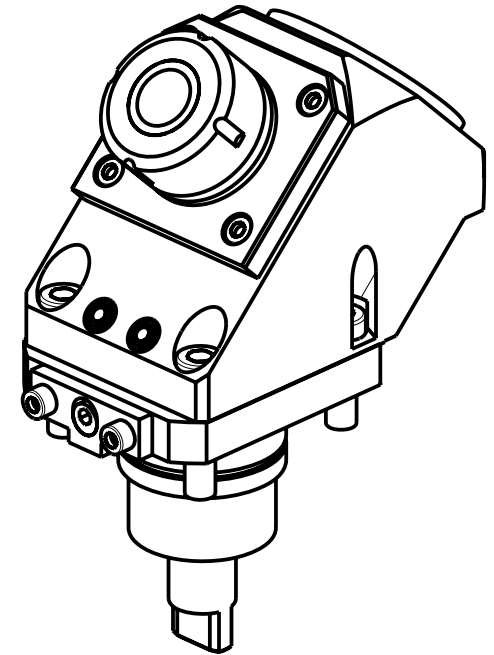

Cod. MT	Cod. BIGLIA	Mandrino Spindle Spindel	I	RPM	Lubrificazione int. Coolant through Innenkuehlung	Lubrificazione est. Ext. coolant Aussenkuehlung	CHIAVI NON INCLUSE Keys not included Schlüssel nicht einbegriffen	
0230032	-	ER32	2:1	2000		X	CHSTER32	CHUB13

BIGLIA
 MOD: B301/445/470/501(Y-S)/510/545/550/565/650/658/1200

MODULO MOTORIZZATO ANGOLARE 45° FISSO
 45° Fixed angle driven tool
 Angetriebenes Werkzeug 45° Fixwinkel

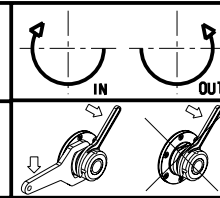

M.T. srl
 Via dei Tamerici 1/3
 Tel. 0541/956034-957884
 Fax 0541/956341
 47842 S. GIOVANNI IN M. (RN)
 e-mail: mima@mtmarchetti.com
 http://www.mtmarchetti.com

PRODUZIONE MODULI ROTANTI



PAGINA BGL357-1-00