

ATTENZIONE - ATTENTION - ACHTUNG

- Su macchine B545, B550, B565 non arriva in centro mandrino
- On machines B545, B550, B565 tool does not get to the centre of the spindle axis.
- Auf Maschinen B545, B550, B565 erreicht das Werkzeug nicht die Mitte der Werkzeug-Achse.

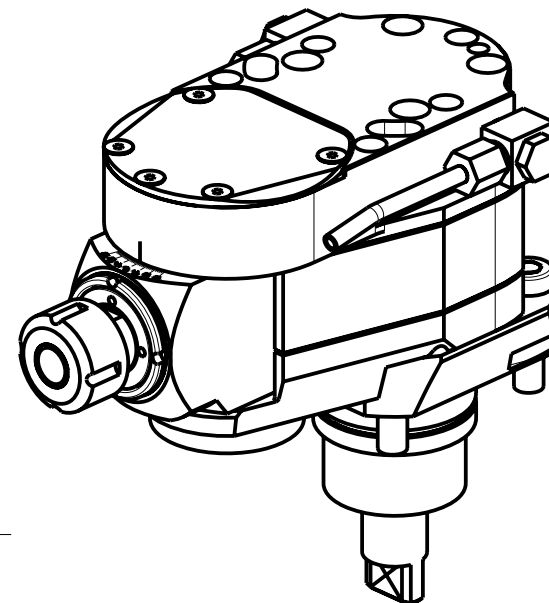

Cod. MT	Cod. BIGLIA	Mandrino Spindle Spindel	I	RPM	Lubrificazione int. Coolant through Innenkuehlung	Lubrificazione est. Ext. coolant Aussenkuehlung	CHIAVI INCLUSE Keys included Schluessel inbegriffen		
0250020	-	ER20	1:1	4000		X	CHSTER20	CHESL08	CHUB13

BIGLIA

MOD: B301/445/470/501(Y-S)/510/545/550/565/650/658/1200

MODULO MOTORIZZATO INCLINEVOLE ±15° IN Y

±15° Y axis adjustable angle driven tool

Angetriebenes Werkzeug kippbar ±15° in Y

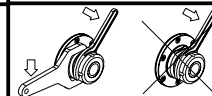

M.T. srl

Via dei Tamerici 1/3
Tel. 0541/956034-957884
Fax 0541/956341

47842 S. GIOVANNI IN M. (RN)
e-mail: mima@mtmarchetti.com
http://www.mtmarchetti.com

PRODUZIONE MODULI ROTANTI



PAGINA BGL358-1-00