

**ATTENZIONE - ATTENTION - ACHTUNG**

- VERIFICARE LE MISURE DI INGOMBRO PER POSSIBILE INTERFERENZA SU ALCUNI MODELLI DI MACCHINE
- Please check the overall sizes for possible interferences on some machine models
- Bitte überprüfen sie das ausmass um mögliche interferenzen auf einigen maschinen modellen zu vermeiden

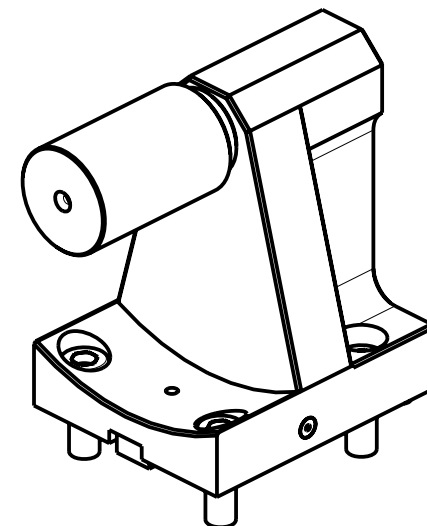

Cod. MT	Cod. BIGLIA	N°Utensili N°Tools N°Werkzeuge	D	L
0800100	-	1	38	125
0800100L	-	1	2"	131.4

NEW

BIGLIA

MOD: B301/445/470/501(Y-S)/510/545/550/565/650/658/1200

CONTROPUNTA PER CONTROMANDRINO

Tailstock for subspinder

Gegenspitz fuer Gegenspindel

**M.T. srl**

Via dei Tamerici 1/3  
Tel. 0541/956034-957884  
Fax 0541/956341  
47842 S. GIOVANNI IN M. (RN)  
e-mail: mima@mtmarchetti.com  
<http://www.mtmarchetti.com>

PRODUZIONE MODULI ROTANTI



PAGINA BGL950-1-00