

ATTENZIONE - ATTENTION - ACHTUNG

- Per lo smontaggio degli utensili utilizzare sempre la chiave di contrasto come indicato nel manuale d'uso.
- For disassembly of the tools use always the contrast key as mentioned in the user instructions.
- Fuer das Abmontieren der Werkzeuge immer den Gegenschlüssel benutzen wie in der Bedienungsanleitung erwäehnt.

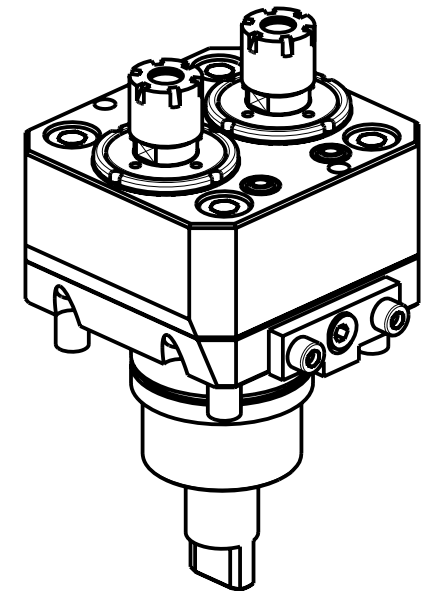

Cod. MT	Cod. BIGLIA	Mandrino Spindle Spindel	I	RPM	Lubrificazione int. Coolant through Innenkuehlung	Lubrificazione est. Ext. coolant Aussenkuehlung	A	CHIAVI NON INCLUSE Keys not included Schluessel nicht einbegriffen	
0150016X2	41.32.30.00	ER16	1:1	4000		X	84.5	CHMNER16	CHUB17
0150025X2	-	ER25	1:1	4000		X	85	CHSTER25	CHUB36

BIGLIA

MOD: B301/445/470/501(Y-S)/510/545/550/565/650/658/1200

MODULO MOTORIZZATO RADIALE 2 USCITE SOVRAPPOSTE

Radial single side twin head driven tool

Radial angetriebenes Werkzeug 2 Ausgaenge ueberlagert

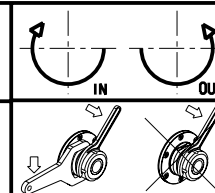

M.T. srl

Via dei Tamerici 1/3
Tel. 0541/956034-957884

Fax 0541/956341

47842 S. GIOVANNI IN M. (RN)

e-mail: mima@mtmarchetti.com

<http://www.mtmarchetti.com>

PRODUZIONE MODULI ROTANTI



PAGINA BGL080-1-00